

# CORIAN® SOLID SURFACE THERMOFORMING

---

## Introduction

This fabrication bulletin addresses basic thermoforming of Corian® Solid Surface sheet.

## Overview

Thermoforming is a process by which Corian® Solid Surface sheet is heated until it softens, then formed into a two or three dimensional shape and cooled. Applications with simple two-dimensional bends can be fabricated fairly easily, while complex three-dimensional shapes can be fairly complicated to fabricate and are beyond the scope of this document. A key principle is to favor compressing the solid surface over stretching it. Thermoforming can be an iterative process, with the mold design, the shape of the blank to be formed, and the forming conditions all important.

## A. Tools Required

### PROTECTIVE EQUIPMENT

Both the ovens and heated sheet have the potential to cause serious burns. In addition to standard protective equipment, insulated gloves are required. Inspect the gloves before use as thin spots, holes, adhesive or moisture can all reduce insulation resulting in burns. If forming multiple parts consider having multiple gloves per person as sweat will reduce the effectiveness of the insulation. Gauntlets are recommended to protect arms if long sleeves aren't worn.

Leather gloves should be worn for handling room temperature sheet and molds. Eye protection and steel-toed shoes should be worn at all times.

### OVEN

Dual platen ovens are preferred for their consistency and speed of heating. Air circulating ovens may be used, but it may be more difficult to obtain uniform sheet temperatures and heating takes approximately five times as long as a platen oven. The ovens should be capable of reaching 200°C (392°F). Temperature uniformity is a key to consistent forming. If the lower platen of an oven does not slide out and reaching into the oven is required the upper platen should be blocked so it cannot close while someone is reaching for a part.

### MOLDS

Molds can vary greatly depending on application and desired mold lifetime. Surfaces should be smooth and the mold material should not cool the formed part rapidly.

A vacuum membrane press is often used with single-sided molds.

Molds can also serve to hold parts for trimming operations.

### TEMPERATURE MEASUREMENT

There are a variety of methods to measure temperature. For sheet temperatures, infrared thermometers are very useful as they can read temperatures by simply pointing the thermometer at the sheet or the membrane of a vacuum press. There are also indicator strips, which change color to indicate the maximum temperature reached. While cheaper, these are not as accurate.

Infrared thermometers however, are not as effective for determining oven temperatures as the accuracy of the measurement is affected by the cleanliness and oxidation of the metal surface. A contact thermocouple is best for measuring platen temperatures. A standard thermocouple is best for air temperatures in an air circulating oven and internal sheet temperatures. Digital thermometers are available that accept multiple types of thermocouples.

### TIMER

A clock or stopwatch may suffice, but it is best to have a timer that will alarm after a set time period.

### LOCATION

Variable room conditions will cause variable results. Ideally the room with the oven and molds will be temperature controlled. If air currents are an issue, consider installing curtains in the thermoforming area to minimize temperature variation.

## B. Material Capability

Thermoformability varies by aesthetic. The limits provided here are the best performing colors. Solid, lighter colors will perform better than darker colors and colors with larger particulates. It is important to understand the characteristics of the aesthetic to be formed. Prior success with a different color is not a guarantee of success.

Table B-1 is a guide to the minimum inside radius for two dimensional bends. Three dimensional forming is much more complex, but local elongation should not exceed 10%. A simple way to evaluate whether a part can be formed on three dimensional molds is to use kraft paper. Try forming the paper over the mold. Areas with excessive wrinkling will be potential problems. Consider forming in multiple pieces and seaming to address these areas.

**TABLE 1: DESIGN DECISIONS; INTERIOR WALL VERTICAL**  
**TABLE B-1**

Sheet Thickness	Minimum Inside Radius
6 mm (1/4")	25 mm (1")
12 mm (1/2")	76 mm (3")
19 mm (3/4")	127 mm (5")

### C. Thermoforming Blanks

The shape of the blank, or piece to be formed, can be a critical factor in successful thermoforming. For two-dimensional forming the blank will be close to the final dimensions. Some excess should be allowed for trimming. The edges will not be square after forming due to deformation.

For three-dimensional forming it is often desirable to have as little excess as possible. In many shapes the maximum deformation is near the edge of the part and there will be a strong tendency to wrinkle.

When developing prototypes it is often useful to mark a grid on the Corian® Solid Surface before forming. The deformation of the grid will help you understand how the material deforms and what the blank shape should be.

When creating blanks that require a tight dimensional tolerance to work successfully it is important to track the original orientation of the blank within the sheet it is cut from. The sheet retains some residual stress from manufacturing that is relieved during thermoforming. This results in a very slight reduction in length and growth in width and thickness. Alternatively the sheet could be annealed before cutting. Annealing is performed by heating the sheet to thermoforming temperatures and then cooling very slowly and evenly, typically by just turning the oven off. This process does take hours and generally isn't necessary.

**Corian® Solid Surface is sensitive to notches when formed. Any notches or defects at the edge of the sheet can lead to tearing. Remove any rough edges from cutting. It is also recommended that the edges be eased slightly.**

Do not attempt to form seamed sheet. If seams are required, the sheet must be formed, trimmed, and then seamed.

### D. Molds

Molds can be a significant part of the overall cost of a project, particularly for large molds that only need to be successfully used once. Mold material selection can vary, taking into account the number of parts needed, shape required, surface finish required, etc.

Wood-based materials (MDF, plywood, pine, hardwood) are commonly used for low cost, rapidly manufactured molds. Wood-based materials do have disadvantages. Grain may leave a pattern on the molded surface. Sap or glue may leave residue on the surface. Longevity is also limited, as water in the mold heats up rapidly it damages the mold over repeated cycles. The molds are also heavy. Aluminum filled epoxy paint applied to the surface of the mold will create a smoother surface and extend the mold lifetime.

Synthetic mold materials are also available. These materials machine well and last longer, but are heavy and expensive.

Both wood-based and synthetic molds are most commonly made using a CNC, though they may also be fabricated by hand.

For high volume molding, composite or metal molds may be attractive. They provide a good finish and long life, but are much more expensive and require skill and equipment that most fabrication shops may not have. Metal molds do have special requirements. Due to the high heat conductivity and heat capacity, metal molds can cool the solid surface too rapidly. In many cases metal molds should be heated to allow slow cooling of the molded part.

#### OTHER DESIGN CONSIDERATIONS:

Molds may be male, female, a combination of both, or two-sided. A two-sided matching mold with both male and female sections is shown in Figure D-1. To reduce the risk of wrinkling when molding deep shapes, a male mold is preferable to a female mold. If a piece is to have a surface texture imparted by the mold, the mold is determined by the convexity/concavity of the surface to be textured: a textured concave surface requires a male mold, while a textured convex surface requires a female mold

Many molds have features to help locate the blank on the mold.

**Figure D-1**

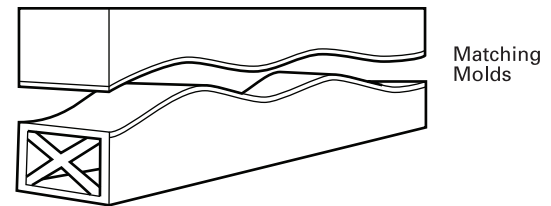

Part release is another consideration. A deep and/or steep piece formed over a male mold will shrink around the mold as it cools and may stick to the mold. Incorporate a 5-degree (minimum) release angle into the mold (See Figure D-2). If a negative draft angle is required, a multiple-part mold that comes apart to release the solid surface is required.

**Figure D-2**

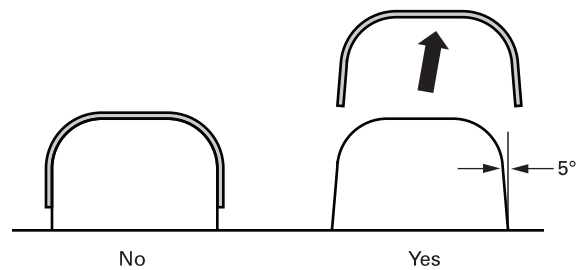

“Helper pieces” can be used in addition to the mold to do some initial shaping before vacuum membrane is activated or work with the vacuum membrane to help forming in difficult spots as shown in Figure D-3.

Figure D-3

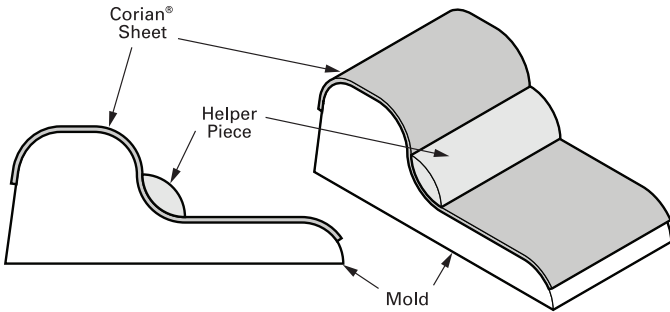

When using a female mold, bevel the cavity edges to prevent the material from being trapped between the forming membrane and the edge of the cavity. Make sure nothing inhibits smooth motion of the material as the membrane presses it into the cavity. This will allow the material to move fully into the mold. Above all, do not allow the material to get caught over a sharp edge. This is shown in Figure D-4 where excess material is trapped between the mold and the membrane, preventing it from drawing into the cavity.

Figure D-4

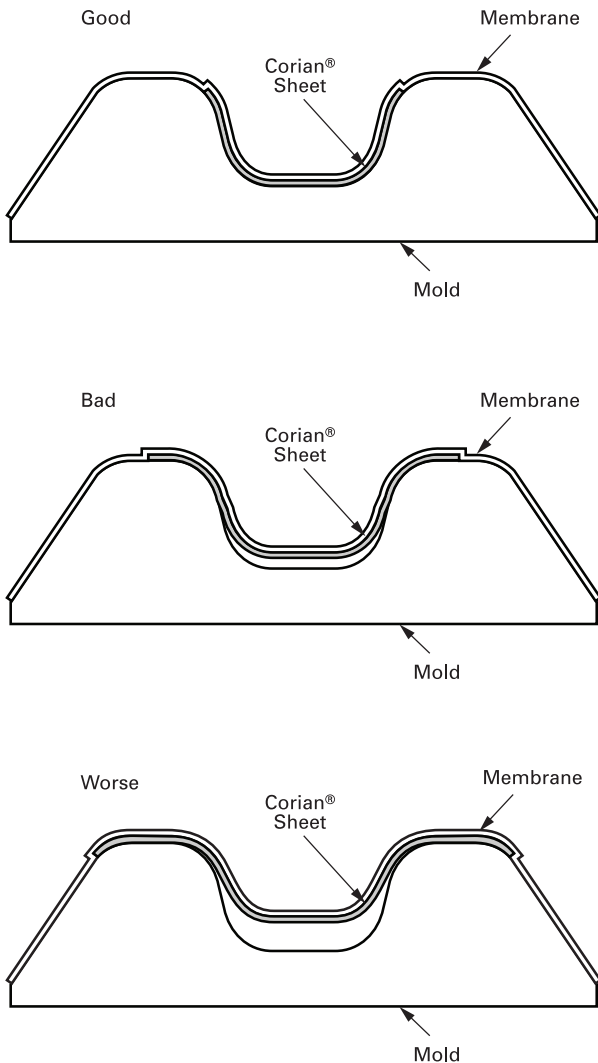

## E. Oven Calibration

### Steps to completion:

1. Drill a  $\frac{1}{32}$ " (0.8 mm) diameter hole halfway into a test piece of Corian® sheet. The sample should be at least 6" x 6" (150 mm x 150 mm). Put the hole near the center of the sample.
  2. Insert the thermocouple wire into the hole, bend it to fit and tape it in place.
  3. Insert the thermocouple wire plug into a digital thermometer. Turn on the thermometer; which should now show the temperature of the sample.
  4. If not using an infrared thermometer, apply a temperature-indicating label near the end of the wire.
  5. Set the oven to the intended temperature and allow the oven to come to a stable temperature for at least 20 minutes.
  6. Put the test sample in the oven and start the timer.
  7. When the temperature on the thermometer reaches within 10°F (5°C) of the oven set point temperature write down the timer reading and remove the piece from the oven.
  8. Read the surface temperature with the infrared thermometer or inspect the temperature-indicating label and note which dots turned black.
- The surface temperature should be approximately the same as the oven temperature. If not, check the calibration of the temperature monitoring equipment.
9. Place the hot sample into the mold, and allow the piece to cool until the thermometer reads 180°F (82°C).
  10. Note the timer reading. This is how long each piece should be cooled in the mold. This is the minimum time that parts should be cooled. If multiple parts are formed the cooling time will be extended as the mold warms.

Figure E 1

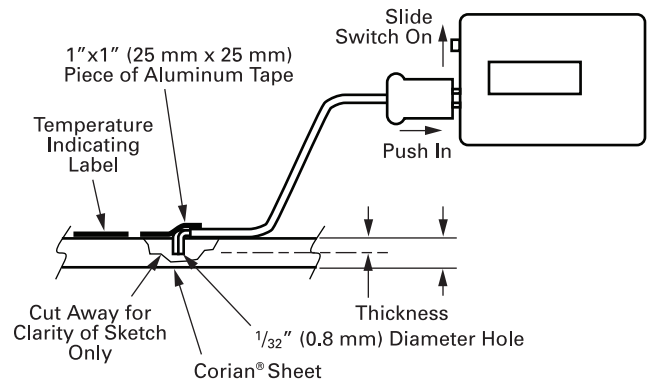

## F. Heating Sheet in a Platen Oven

A platen oven has heated plates that will heat sheets much more quickly than an air circulating oven. This results in higher productivity. The platen press must be capable of uniform heating up to 200°C (392°F).

**The upper platen is hot and heavy. If the design requires reaching into the oven the upper platen should be blocked when adding or removing sheet. This will prevent the oven from closing on someone who is reaching for a part.**

The platen oven should be set to the desired sheet temperature. Place the Corian® sheet into the preheated platen press with the heat setting between 300° and 325°F (150° and 165°C). A rough guideline is that the sheet should be heated one minute for every millimeter, so 6 mm (1/4") for 6 minutes, 12 mm (1/2") for 12 minutes.

These times may vary with oven design. Follow the oven calibration procedure to determine the proper heating times. Note that the time for heating may vary with the size of the part and the rate at which the oven returns to its temperature set point after the sheet is inserted.

### HELPFUL HINTS

*The heating times provided assume the sheet is at typical room temperatures. Temperatures well above or below room temperature will affect heating times.*

*If sheet is not stored in a climate controlled building, consider bringing it into the shop the day before so it conditions overnight.*

### STEPS TO COMPLETION:

1. Preheat the platen oven to the desired forming temperature. Make sure the temperature is stable.
2. Have everything needed (safety equipment, thermometer, mold, etc.) ready and accessible.
3. Wearing thermal gloves and gauntlets place the blank in the platen oven. If you are forming a small sample insert spacing blocks if necessary.
4. Close oven and start timer. Generally 6 minutes for 6 mm (1/4") sheet or 12 minutes for 12 mm (1/2") sheet.
5. When the blank has been in for the designated time, open the oven. If the platen oven has a sliding lower surface it is good practice to scan the surface with an infrared thermometer to check that the sample is the correct and uniform temperature.
6. Transfer the blank to the mold.
7. Follow the instructions in the following sections for the specific type of mold used.

**Corian® Solid Surface is very rubbery at thermoforming temperatures and larger blanks may be difficult to handle. Make sure enough personnel wearing proper protective equipment are available to help transfer the blank safely. Burns will result if sheet makes direct contact with bare skin.**

### HELPFUL HINTS

*Make sure the oven is clean. Any dirt or residue will transfer to the sheet and may become embedded in the surface, requiring additional sanding to remove.*

*If thermoforming small pieces, use some scrap samples evenly spaced in the oven so the platen lowers evenly on the part to be formed.*

*If writing on the sheet to identify parts, be aware that the ink can transfer to the oven platens and onto future sheets. Consider removing labels before heating sheets.*

## G. Heating Sheet In An Air Circulating Oven

Air circulating ovens can be used successfully, but it is important to understand the oven. Heating is much slower than in platen ovens. It will take approximately 5 minutes per millimeter (6 mm [1/4"] - 30 minutes, 12 mm [1/2"] - 60 minutes) in order to uniformly heat sheet to the oven temperature. It is important to calibrate and understand the characteristics of the oven.

Air circulating ovens rely on air circulation to maintain uniform temperatures. This air circulation will be disrupted by the thermoforming blank. An oven that heats uniformly with small samples may have poor temperature control if the blank is near the size of the oven.

Fabricators will often set the oven temperature higher than the desired sheet temperature to reduce the heating time. This is feasible, but it's important not to set the temperature above 400°F (205°C). The sheet itself should not be allowed to exceed 350°F (177°C) as there is a risk of overheating. The sheet temperature will not be uniform when removed from the oven. The blank should be allowed to "rest" 1-2 minutes so the center and surface temperatures can equilibrate. Careful calibration studies should be done to develop an understanding of the proper times and temperatures (note this may vary with blank size) if setting the oven to a higher temperature.

### STEPS TO COMPLETION:

1. Preheat the air circulating oven to the desired forming temperature. Make sure the temperature is stable.
2. Have everything needed (safety equipment, thermometer, mold, etc.) ready and accessible.
3. Wearing thermal gloves and gauntlets, place the blank in the air circulating oven.
4. Close oven and start timer. Generally 30 or 60 minutes (for 6 mm [1/4"] and 12 mm [1/2"] sheet, respectively) will be required.
5. When the blank has been in for the designated time, open the oven. It is good practice to scan the surface with an infrared thermometer to check that the sample is the correct and uniform temperature.
6. Transfer the blank to the mold.
7. Follow the instructions in the following sections for the specific type of mold used.

## H. Infrared Ovens (Not Recommended)

Infrared or radiant ovens are commonly used for heating unfilled plastics. When used with unfilled plastics the infrared radiation can partially penetrate the sheet, heating uniformly. Filled polymers, such as Corian® Solid Surface, do not transmit infrared radiation and all the energy is absorbed at the surface. The ability to heat the surface faster than the interior can transfer heat often results in thermal damage at the surface with a center still too cool to form. Infrared ovens are NOT recommended for heating solid surface materials.

## I. Spot Heating (Not Recommended)

Corian® Solid Surface should always be uniformly heated and cooled to minimize stress in the final part. Spot heating will create stress within the material. This stress may lead to failure in later processing steps or in use. Spot heating is NOT a recommended practice.

## J. Forming

The forming process will vary depending on the mold type. It is important to remember that the thermoforming blank starts cooling as soon as it is removed from the oven. The amount of time that one can work with the material will vary based on the room conditions and the mold type and temperature.

The mold should be ready before beginning to heat the sheet. If using lubricants such as wax or talc, apply them before starting the heating process. Sometimes it is desirable to have the mold heated before forming. If forming multiple parts sequentially the mold will warm up, increasing the cooling time of the part and perhaps changing the results. Preheating the mold before the first part will aid in having a consistent process. More time is available to work with the blank if the mold is warm.

Placing the blank in the correct place on the mold is important. One can also start to shape the blank in the mold using hands (using proper thermal gloves). If forming using a vacuum membrane press, forming can be assisted using hands pressing on the membrane. This helps control wrinkling.

Figure J-1

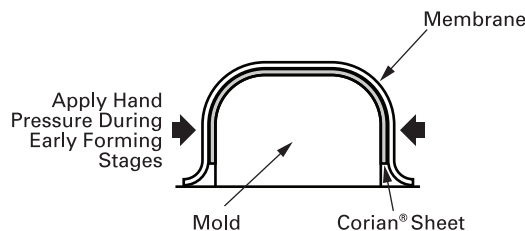

## STEPS TO COMPLETION:

1. Remove the hot blank from the oven.
2. Position on the mold. Having alignment features built into the mold facilitates proper positioning.
3. Do any hand preshaping or use auxiliary forming pieces
4. Depending on the mold, the blank should be clamped in place, the mold closed, or the vacuum membrane lowered.
5. Allow the part to cool to 180°F (82°C). The time required to cool will depend on the room temperature, mold temperature and the mold construction. Expect up to 30-45 minutes for 12 mm (1/2") sheet. Some parts can be cooled to room temperature, but if a male mold is used a part can be difficult to remove if completely cooled. If using a vacuum membrane, an infrared thermometer can be used to read the temperature of the membrane. It will generally be a few degrees cooler than the sheet. For other molds, use scrap pieces with thermocouples to establish cooling times.

## HELPFUL HINTS

*Vacuum membrane presses are very useful, but the silicone membranes are prone to tearing and are expensive to replace. A little extra care in mold design and forming techniques can greatly extend the life of the membrane. Some tips are:*

- Eliminate sharp corners on molds
- Look for places where the membrane would have to bridge a gap and stretch significantly and fill that space.
- Use helper pieces such as in Figure D-3. The membrane will not have to stretch as much.

## K. Rebating Technique

Selectively thinning or rebating the blank is useful in some designs. Impact resistance will be lower in the thinned sections. Thin the material using a router. It is important to have a 1/4" (6 mm) radius at the transition between the two thicknesses. An example is shown in Figure K-1 where a deal tray is being formed in a horizontal top. Make sure the routed area is smooth. Any variation in thickness may telegraph to the top surface.

Figure K-1

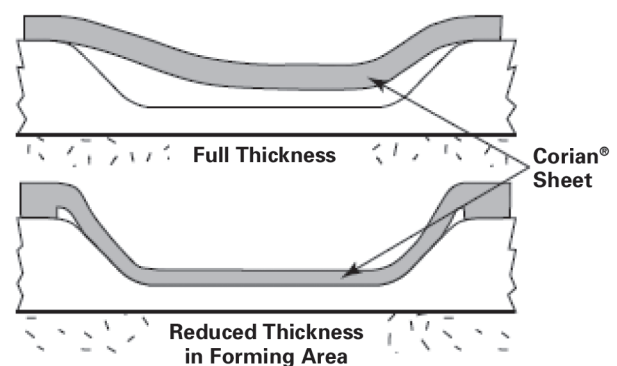



## L. Trimming and Finishing

Thermoformed parts will generally need some trimming and finishing. The edges of the formed part will no longer be square. If precise dimensions are required the part needs to be trimmed after forming. Some times the mold can be used to hold the part for finishing. Other times a dedicated fixture will be required.

In general, some finishing will be required. The degree of finishing required will depend on the color formed and the quality of the mold surface. A solid color with a high quality mold surface may need only to be touched up with a non-woven pad. Colors with particulates or formed on a rougher mold will need to be sanded smooth.

## M. Process Development and Troubleshooting

Developing an economical and reliable thermoforming process takes advance planning and attention to detail. It will be important to keep good records to understand which techniques give the best results or to aid in troubleshooting. Thermoforming, more than most processes, can be affected by external factors. Something as simple as a door being left open that creates a draft in the thermoforming area could affect results. An example process record is listed below. Depending on the goal, different data would be recorded. One shop may be looking at mold economics and want to know how long a mold lasts. Another may be trying to understand why they are having inconsistent results, only to find that they always have problems for the first few parts on Mondays and institute a practice of preheating molds.

### EXAMPLE PROCESS RECORD

- Material (color and gauge)
- Operating procedure
- Blank template or program
- Oven temperature
- Mold ID
- Mold temperature (before and after)
- Heating and cooling time
- Trim fixture or program
- Number of parts produced on mold
- Day/Time
- Ambient temperature
- Operator
- Success or failure
- Process aids used (talc, wax, etc.)

Having a written operating procedure helps ensure consistency and also helps identify changes in techniques that occur.

There is no “best” way to form parts. A shop that does custom, one-of-a-kind parts will have different considerations than one trying to manufacture many identical parts.

The following is a list of considerations for process and part design, optimization, and troubleshooting.

### PROCESS DEVELOPMENT/OPTIMIZATION

- If the goal is increasing your production rate, what is the limiting factor? A platen oven can provide blanks for several molds as heating is faster than cooling. But an air circulating oven may only be able to provide blanks for one mold.
- Forming broad arcs? Form at a lower temperature. The increased stiffness will help form a natural arc.
- Minimize deformation as much as possible. It's preferable to have the material slide across the mold versus stretching. Also, compression is preferable to stretching.
- Understand the trade-offs in mold material design including cost, lifetime, quality, etc.
- There may be a slight color shift when heating lighter colors. If the thermoformed part will be seamed to a flat sheet it is a good idea to heat the flat sheet as well.

### TROUBLESHOOTING

- Whitening is caused by many small failures in the part that scatter light. Possible causes include:
  - Temperature isn't high enough – possible causes include: wrong set point, oven not operating correctly, sheet not heated long enough, or sheet was excessively cold going into oven.
  - Surface cooled off before forming – possible causes include: too much time from oven to mold or too much time positioning on the mold.
  - Exceeding maximum draws – possible causes include: too tight a bend, too much elongation, or the blank may be trapped during the molding process and unable to move relative to the mold.
- Wrinkling generally occurs in area where the material is compressed and it is easier for the sheet to buckle than compress. Possible causes include:
  - Excessive compression – make sure compression is under 10%. It may be necessary to break the part into multiple pieces and seam after forming. Kraft paper can be used to predict where the material will begin to buckle.
  - Mold design doesn't provide resistance to buckling– sometimes this can be addressed by hand assistance during forming, but changes to mold design may be required such as moving to matched molds, switching from female to male molds, etc.
  - Blank has excess material – the greatest compression is often at the edge of the part. Optimize the blank geometry to minimize excess material.

## CORIAN® SOLID SURFACE THERMOFORMING

---

- Tearing can have multiple causes
  - If the tear starts at the edge of the blank or if multiple small fractures are visible then check the quality of the blank edge. A rough saw cut or nick can cause failures during forming. Edges should be smooth and eased slightly.
  - The blank may be pinched by the mold or by the vacuum membrane, preventing it from moving. Try preforming by hand or with a helper piece. A lubricant (talc or wax) may help the part slide.
  - The part tears in or around particulates. The capability of the color may have been exceeded. Colors with large particulates do not form as well and some may require radii of 6" (150 mm) or more. Better success may be obtained by lowering the temperature slightly. Rebating in the formed area is also an option.
- The surface requires excessive sanding
  - If the show face is against the mold, check the mold finish.
  - Colors with larger particles will tend to be rougher. The roughness will be greater if the show face is away from the mold during forming. If possible, form the show face against a smooth mold.
- Inconsistent results – this is where a good process record is essential.
  - If consistent success changes to constant failure double check your equipment. There may be problems with the oven (either heater, or calibration). Verify that the part is coming out of the oven at the correct temperature and that the temperature is uniform. Use a scrap piece and a thermocouple to check the internal temperature.
  - If results become erratic, track the mold temperature before and after forming, as well as the ambient temperature. Is the sheet always the same temperature going into the oven? Has the thermoforming area temperature changed? Is there a new airflow pattern (i.e. a door is open creating a draft)? Are there problems with the first part of the day, or do problems develop as the mold warms up?
  - Different personnel get different results – There is a bit of art involved in forming that is gained by experience and may not be captured by formal procedures. Observe personnel closely. One may be positioning the blank slightly differently or assisting by hand where the other is not.

PLEASE VISIT OUR WEB SITE: [WWW.CORIAN.COM](http://WWW.CORIAN.COM) OR CONTACT YOUR CORIAN® REPRESENTATIVE  
FOR MORE INFORMATION ABOUT CORIAN® SOLID SURFACE

This information is based on technical data that DuPont Specialty Products USA, LLC and its affiliates ("DuPont") believe to be reliable, and is intended for use by persons having technical skill and at their own discretion and risk. DuPont cannot and does not warrant that this information is absolutely current or accurate, although every effort is made to ensure that it is kept as current and accurate as possible. Because conditions of use are outside DuPont's control, DuPont makes no representations or warranties, express or implied, with respect to the information, or any part thereof, including any warranties of title, non-infringement of copyright or patent rights of others, merchantability, or fitness or suitability for any purpose and assumes no liability or responsibility for the accuracy, completeness, or usefulness of any information. This information should not be relied upon to create specifications, designs, or installation guidelines. The persons responsible for the use and handling of the product are responsible for ensuring the design, fabrication, or installation methods and process present no health or safety hazards. Do not attempt to perform specification, design, fabrication, or installation work without proper training or without the proper personal protection equipment. Nothing herein is to be taken as a license to operate under or a recommendation to infringe any patents. DuPont shall have no liability for the use of or results obtained from such information, whether or not based on DuPont's negligence. DuPont shall not be liable for (i) any damages, including claims relating to the specification, design, fabrication, installation, or combination of this product with any other product(s), and (ii) special, direct, indirect or consequential damages. DuPont reserves the right to make changes to this information and to this disclaimer. DuPont encourages you to review this information and this disclaimer periodically for any updates or changes. Your continued access or use of this information shall be deemed your acceptance of this disclaimer and any changes and the reasonableness of these standards for notice of changes.

The Corian® Solid Surface Logo and Corian® and all trademarks and service marks denoted with ™, ® or ® are owned by affiliates of DuPont de Nemours, Inc. unless otherwise noted. © 2023 DuPont.