

EDGE DETAILS AND BUILDUPS

INTRODUCTION

This bulletin addresses the fabrication of DuPont™ Corian® solid surface edge details and buildups.

OVERVIEW

Edge details and buildups serve both as visual design features as well as structural components. There are a variety of design options. The “best” option may vary by the design preference, color of DuPont™ Corian® solid surface, the design, or by the capability of the fabricator. It is important that the fabrication is done correctly, as improper fabrication may lead to product failure.

A. FABRICATING FOR DURABILITY

Any time there is a change in dimension or a flaw in the surface there is a concentration of stress, often referred to as a stress riser. If not properly addressed, the increased stress level may lead to eventual failure. Properly designed edge buildups will help strengthen the assembly. Changes in dimension are addressed by including a radius. This is particularly important at inside corners. The larger the radius, the lower the stress at that location. Adding reinforcement also reduces the probability of failure.

Fabrication flaws may also create stress risers. These flaws may be nicks, cuts, chips or seams that aren't completely filled. It is important to have smooth edges and proper seams.

B. RABBETING THE UNDERSIDE OF THE DECK

Tools required

- 2-hp router
- Rabbet bit for drop edges or mortising bit for stack edges
- Alternatively a CNC with proper tooling

There are several methods of making edge buildups. Typically either a stack (layered) or a drop (a single upright strip) is used. Following are several ways to assist in making edge buildups.

When the underside of sheets of the particulate color families is uneven or has some air bubbles that will affect the seam quality, rabbeting the underside of the deck is suggested to eliminate the aforementioned problems.

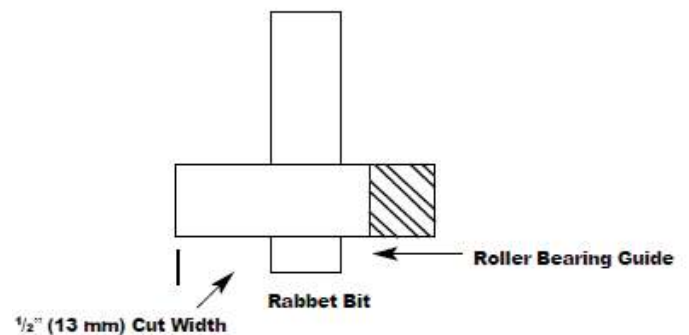

Figure B-1

Steps to completion:

1. Ensure that the countertop is finished to a stage where all countertop seams are complete and the countertop is accurately sized to $1/16$ " (1.5 mm) of its final dimension. This requires that all pocket cuts are complete, especially in inside and outside corners.
2. Fit the router with the proper bit.
3. Rout a $1/2$ " x $5/64$ " (13 mm x 2.0 mm) rabbet along all edges of the countertop that require a drop edge.

HELPFUL HINTS:

The notch bit allows the rabbet to be completed on all straights and curves without turning the countertop over.

Use a router with as large a base as possible, as this prevents any potential tilting during the cut.

C. CONSTRUCTING THE DROP EDGE BUILDUP

Drop edge buildups are as important as inside and outside corners in terms of your ability to create a seamless finish. Drop edges are a more simple process, but are equally important to finish perfectly.

The minimum thickness for a drop edge strip is $7/16$ " (11 mm). Do not over-rout during edge clean up.

Steps to completion:

1. Using material color-matched to the sheet, cut the required number of strips. It is essential that buildup seams do not align with countertop seams. Careful planning is required at this point to ensure that the separation between seams is a minimum of 2" (51 mm).

EDGE DETAILS AND BUILDUPS

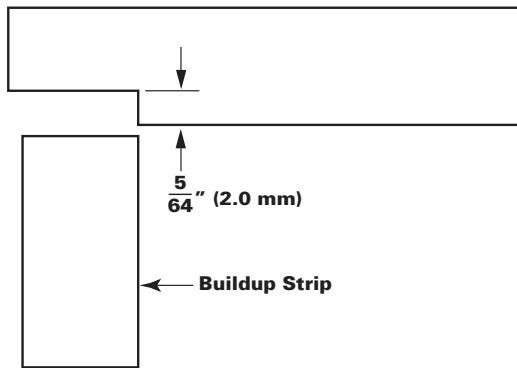

Figure C-1

The width of the strips can be calculated as follows:

Total countertop thickness (A = 38 mm [1.5"])
 minus
 thickness of the DuPont™ Corian®
 sheet (B = 12 mm [0.47"])
 plus
 the depth of the rabbet (C = 2.0 mm [0.08"])
 equals
 width of the strips (D = 28.0 mm [1.10"]).

This is illustrated in Figure C-2.

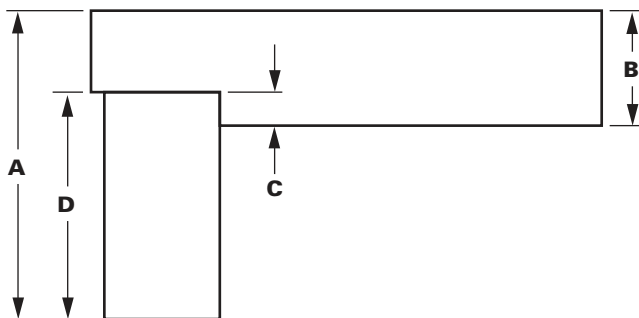

Figure C-2

For large particulate products C and D may be increased to 5 mm and 31 mm respectively. This will improve the uniformity of the size of the particulates.

2. Sand to a smooth finish the edge of the strips to be glued to the rabbeted edge.
3. Turn the sheet over and trial-fit all strips.
4. Apply a generous quantity of DuPont™ Joint Adhesive or DuPont™ Joint Adhesive 2.0 to the seam area, ensuring that the entire rabbeted area has an even coating.
5. Place the buildups in position hard against the rabbet upturn and clamp in position using spring clamps placed every 3" (76 mm).

6. Ensure that the pool of adhesive that forms at the rear edge of the seam is left intact and allowed to cure.
7. Ensure that the pool of adhesive that forms at the front edge of the seam is continuous and left intact.

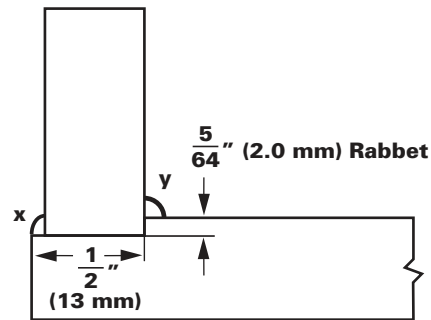

Figure C-3

Allow DuPont™ Joint Adhesive or DuPont™ Joint Adhesive 2.0 to pool at both points x and y in Figure C-3. If pooling is not continuous at point x, reapply additional joint adhesive.

HELPFUL HINTS:

When clamping the buildup strips in place, be especially careful to ensure that they are perfectly aligned at 90 degrees to the countertop. The depth of the rabbet may be adjusted deeper to compensate for perceived particle separation in the edge of the deck.

The usual method to construct drop edge buildups is without using the rabbet method.

Non-Rabbeted Edge Detail

Drop edge strips butted directly against the underside of the Corian® sheet are possible.

When using this technique, be sure to check for defects to the underside of the sheet and sand the strip and the underside of the sheet prior to seaming, if needed.

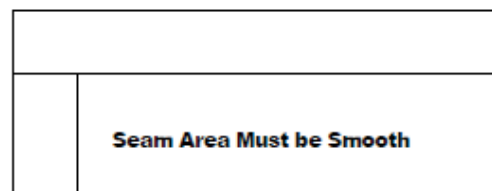

Figure C-4

HELPFUL HINTS:

Use wooden stop blocks glued in place with hot melt glue to perfectly align buildup strips.

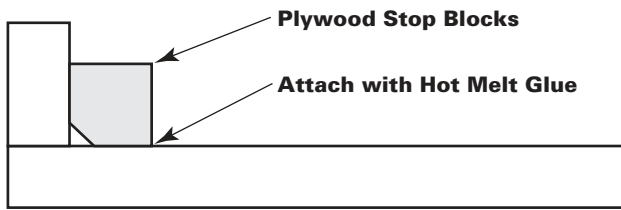

Figure C-5

D. INSIDE CORNER CONSTRUCTION METHODS

One of the major fundamentals in the fabrication of DuPont™ Corian® solid surface is that all inside corners have as large a radius as possible, with the minimum radius being $\frac{1}{2}$ " (13 mm).

There are several ways to fabricate the inside corner on a standard countertop.

Laminated Method

Steps to completion:

1. The countertop seam is placed out of the inside corner. The sheet that forms the "L" shape must be initially cut within $\frac{1}{16}$ " (1.5 mm) of the shape of the final inside corner radius.

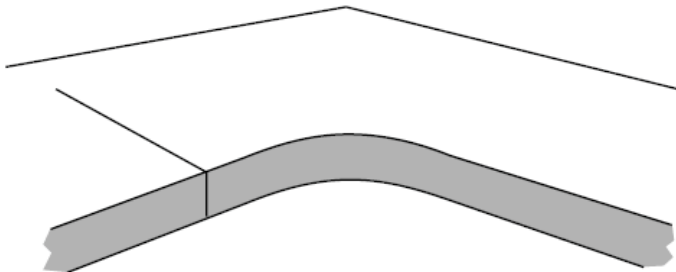

Figure D-1

2. Thicknesses of $\frac{1}{2}$ " (12 mm) Corian® sheet (subject to the required depth of the buildup strip) are sanded, glued and clamped together.
3. They form a square block that is then routed to the exact radius and shape of the internal corner.

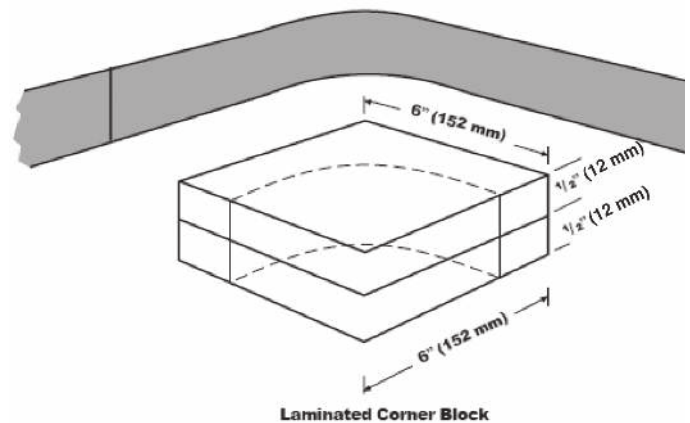

Figure D-2

4. This block is then glued to the underside of the countertop in the inside corner, and forms a guide for a flush-cut trimmer to complete the final shape of the countertop.

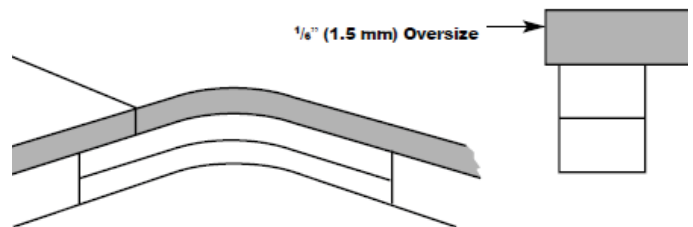

Figure D-3

The butt seam in a buildup edge must be a minimum of 1" (25 mm) past the radius in the inside corner.

Thermoformed Method

Steps to completion:

1. The countertop seam is placed out of the inside corner. The sheet that forms the "L" shape must be cut initially within $\frac{1}{8}$ " (3 mm) of the shape of the final inside corner radius.
2. A strip of color-matched material is then thermoformed as per standard instructions to the required shape and depth of the thick edge.
3. Prepare the edge to be glued against the underside of the countertop to ensure it is perfectly square, as plastic deformation may occur during thermoforming.

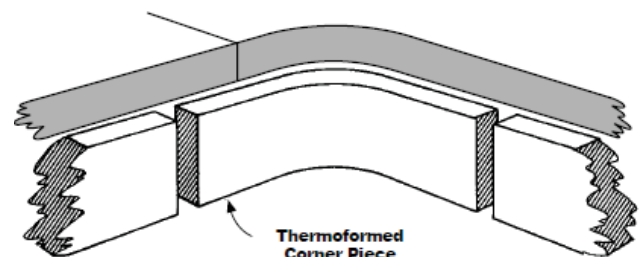

Figure D-4

EDGE DETAILS AND BUILDUPS

- The piece is then glued to the underside of the countertop in the inside corner and forms a guide for a flush-cut trimmer to complete the final shape of the countertop.

Thermoformed piece must be minimum $\frac{7}{16}$ " (11 mm) thick. The minimum inside radius is 3" (76 mm). For more details see *DuPont™ Corian® Solid Surface Fabrication/Installation Fundamentals – Thermoforming (K-25297)*.

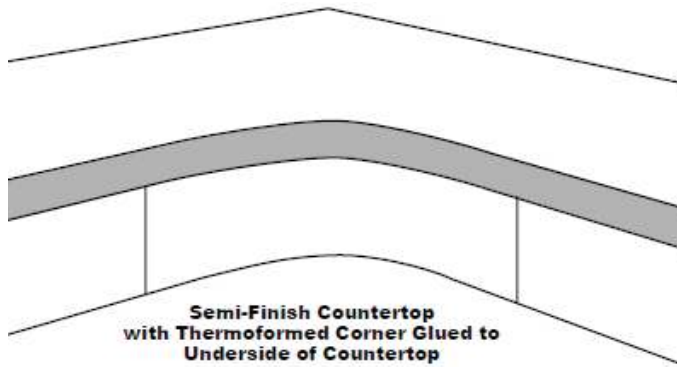

Figure D-5

Corner Insert Method (Laminated)

Steps to completion:

- A standard square corner with a butt seam is made.
- A straightedge buildup is then completed around the entire front edge.
- The seam is then reinforced with the strip fitting flush to the straightedge buildup.

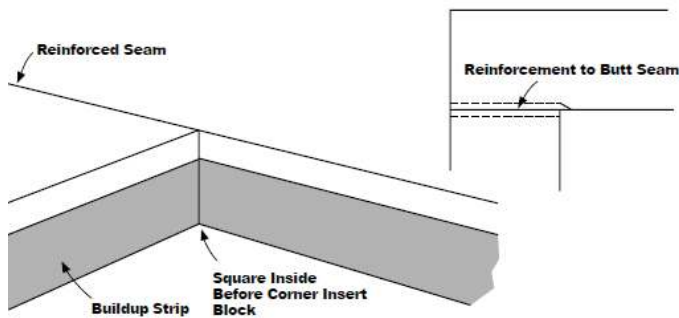

Figure D-6

- The corner insert piece is then added in the inside corner and glued to the front edge buildup.

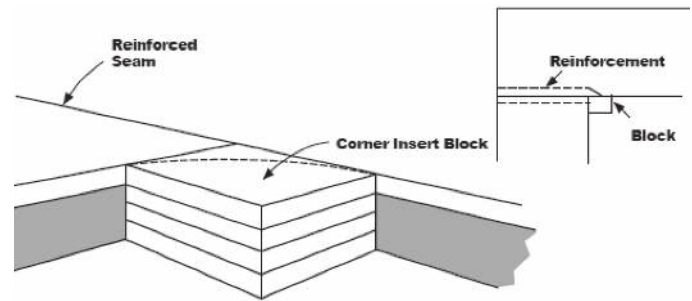

Figure D-7

- The radius is then formed with a router and radius template.

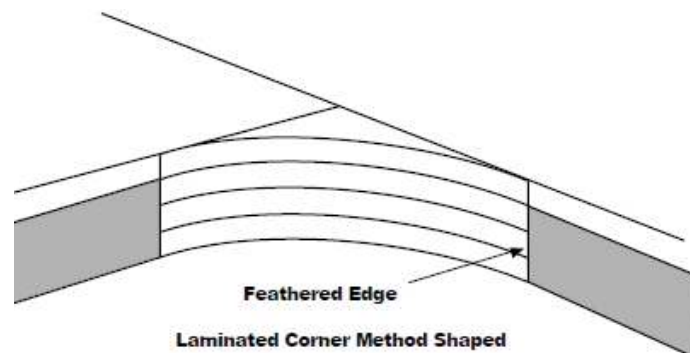

Figure D-8

Corner Insert Method (Thermoformed)

Steps to completion:

- A standard square corner with a butt seam is made.
- The corner insert piece is then added to the inside corner and glued to the edge of the countertop.

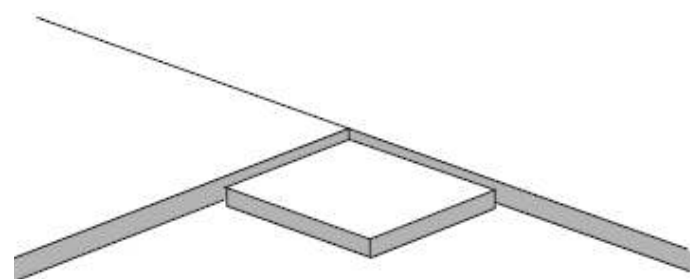

Figure D-9

- The required radius of the inside corner is then routed into the insert block, $\frac{1}{8}$ " (3 mm) oversize.
- The rabbet for the buildup is then completed.
- A strip of color-matched material is then thermoformed to the required shape and depth of the buildup.
- The countertop is then turned over and the thermoformed piece glued to the underside of the countertop to make the inside corner.

EDGE DETAILS AND BUILDUPS

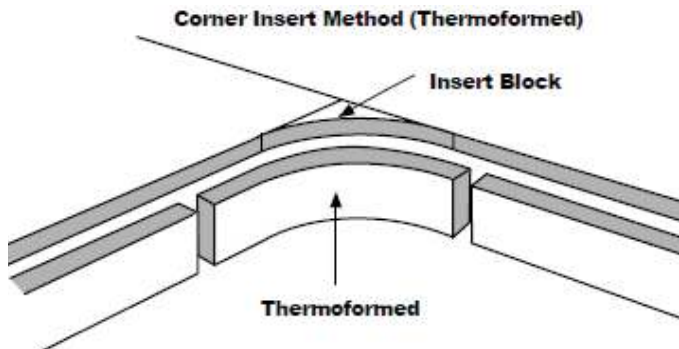

Figure D-10

- The reinforced seam is then completed flush and scribed to the inside corner piece.

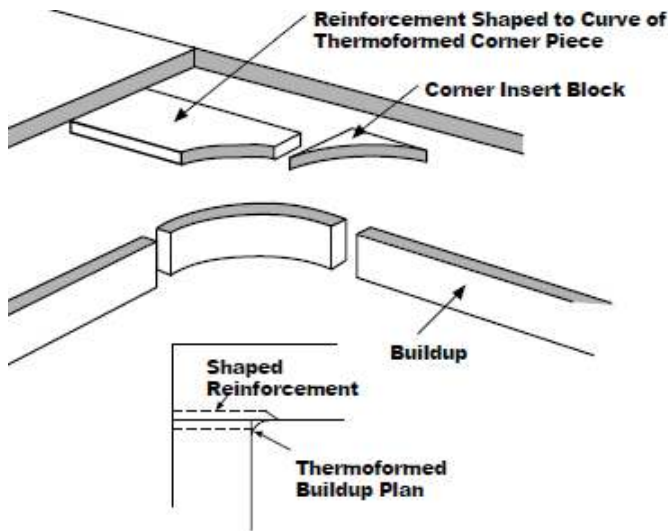

Figure D-11

- The edge buildup is then completed around the entire front edge of the DuPont™ Corian® countertop and butted up to thermoformed inside corners.

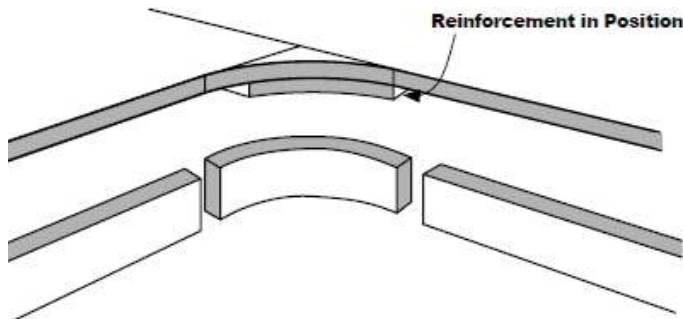

Figure D-12

- The countertop radius is then formed with a router and radius template.

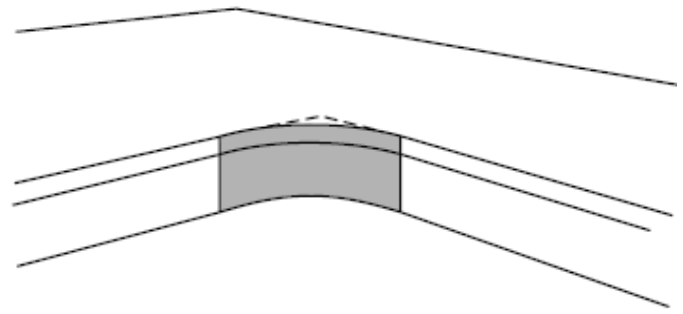

Figure D-13

HELPFUL HINTS:

Never have the seams to the buildup closer than 1" (25 mm) from the radius in the corner.

E. OUTSIDE CORNER CONSTRUCTION METHODS

Like an inside corner, an outside corner can be formed using two methods:

Laminated Method

The Laminated Method for outside corners utilizes the same principles as the Laminated Method for inside corners.

Steps to completion:

- Thicknesses of 1/2" (12 mm) Corian® sheet (subject to the required depth of the buildup) are sanded, glued and clamped together.
- They form a square block that is then routed to the exact radius and shape of the external corner.

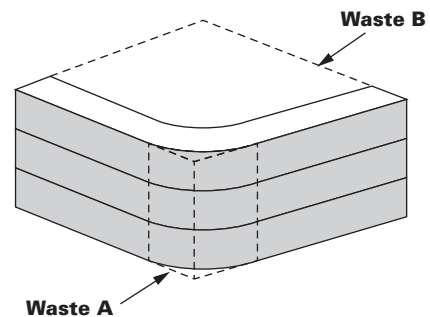

Figure E-1

- This block is then glued to the underside of the countertop at the outside corner and forms a guide for the flush-cut trimmer to complete the final shape of the countertop.

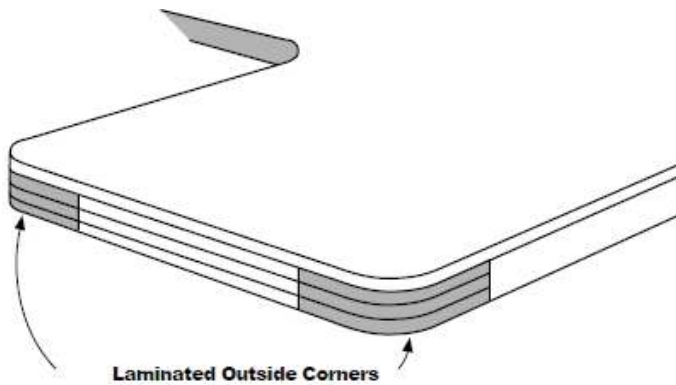

Figure E-2

Thermoformed Method

Steps to completion:

1. A strip of color-matched material the required depth of the buildup is thermoformed as per standard instructions to the required shape and depth of the buildup.

Thermoformed piece must be minimum $\frac{7}{16}$ " (11 mm) thick. The minimum inside radius for thermoforming is 3" (76 mm) and some colors require a larger radius.

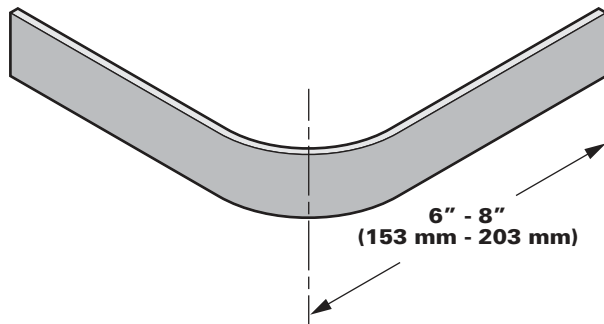

Figure E-3

2. This piece is then glued to the underside of the countertop at the outside corner and forms a guide for the flush-cut trimmer to complete the final shape of the countertop.

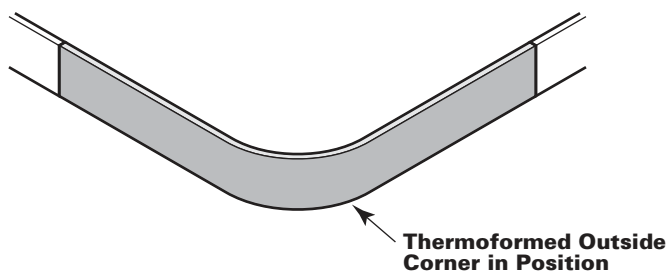

Figure E-4

F. USING THE LAMINATED METHOD FOR INSIDE CORNERS

Steps to completion:

1. Complete the countertop to a stage where all countertop seams are complete. The entire countertop must be finished to a point where all buildup edges, including inside and outside corners, are finished to within $\frac{1}{8}$ " (3 mm) of their final shape and size.
2. Complete a $\frac{5}{64}$ " x $\frac{1}{2}$ " (2.0 mm x 13 mm) rabbet around all edges that require buildup, as per instructions in B. Rabbeting the underside of the deck.
3. Use color-matched material to create blocks 8" x 8" (203 mm x 203 mm), sufficient to make up the required buildup depth.

The number of blocks required in the Laminated Method can be calculated as follows:

(Countertop thickness minus thickness of the sheet plus the depth of the rabbet) divided by 12 mm (0.47") = number of blocks, rounded up to the nearest whole number .

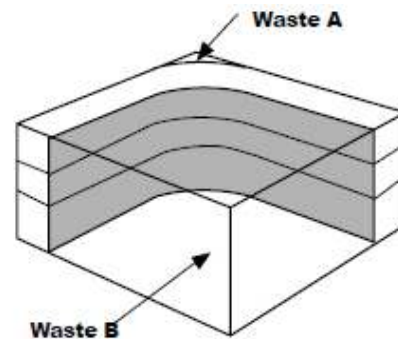

Figure F-1

4. Sand the blocks to ensure a perfectly flush face fit for all blocks.
5. Apply a perfectly even layer (i.e., no "S" pattern or similar) of DuPont™ Joint Adhesive or DuPont™ Joint Adhesive 2.0 to the faces of all blocks to be seamed.
6. Clamp the layers together and allow adhesive to cure.
7. Upon setting, sand two adjoining sides of the block to a smooth finish.
8. Mark block for template position.
9. Using hot melt glue, adhere the partially completed block onto a secure work surface that allows room for a radius template and router.
10. Clamp template to laminate block in a position that ensures that the inside corner radius is at least $\frac{1}{2}$ " (13 mm).
11. Rout along the template to complete the piece.
12. Closely examine the now-formed corner piece for any visible seams. If seams are visible, repeat steps 1–8 (i.e., do not reuse this piece).

13. Double-check that the ends of the inside corner piece are well-finished and perfectly square.
14. Complete straightedge buildup as per instructions in *C. Constructing the drop edge buildup*.
15. Trial-fit all parts for size, alignment and color-match.
16. When sure that all parts are a good fit, apply a generous coating of joint adhesive and clamp all pieces in position.
17. After adhesive has set, turn the sheet over and, using flush-cut router bit, complete the countertop shape by removing the $\frac{1}{16}$ " (1.5 mm) overhang.
18. Complete edge treatments as per instructions in *L. Laminated method alternatives* or *M. Stack Edge*.

G. USING THE THERMOFORMED METHOD FOR INSIDE CORNERS

Steps to completion:

1. Using a color-matched piece of material to the sheet surface, prepare a strip of Corian® solid surface the required depth of the buildup by a length that provides 4" (102 mm) returns from each end of the inside corner radius.
 - Calculate the required depth of the build up by subtracting the thickness of the sheet from the required countertop thickness plus the depth of the rabbet.
 - Calculate the required length of the thermoformed piece by using the following formula:

The circumference of a circle = $2\pi r$ ($\pi = 3.1416$, and $r = \text{radius}$)

A right angle forms 90 degrees (i.e., $\frac{1}{4}$ of a circle), therefore the formula is:

$2\pi r$ divided by 4 plus 2×4 " (102 mm) (for the legs of the piece). So to calculate the required length of the thermoformed piece:

$$\frac{2 \times 3.1416 \times \text{radius}}{4} + 2 \times 4" [102 \text{ mm}]$$

Example:

$$\frac{2 \times 3.1416 \times 4" [102 \text{ mm}]}{4} + 2 \times 4" [102 \text{ mm}] =$$

$$\frac{25.13" [638 \text{ mm}]}{4} + 8" [203 \text{ mm}]$$

$$= 6.283" (160 \text{ mm}) + 8" (203 \text{ mm})$$

$$= 14.283" (\approx 14 \frac{9}{32}) \text{ or } (363 \text{ mm}) \text{ for the length of piece}$$

Thermoformed piece must be minimum $\frac{7}{16}$ " (11 mm) thick. The minimum inside radius for thermoforming is 3" (76 mm) and some colors require a larger radius.

2. Using the techniques detailed in *DuPont™ Corian® Solid Surface Fabrication/Installation Fundamentals – Thermoforming* (K-25297), thermoform the strip to the required radius.

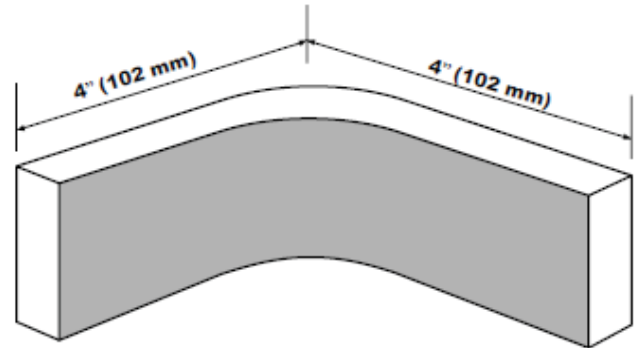

Figure G-1

3. Prepare the edge to be glued against the underside of the countertop to ensure it is perfectly square, as plastic deformation may occur during thermoforming.
4. The piece is then glued to the underside of the countertop at the inside corner and forms a guide for the flush-cut trimmer to complete the final shape of the countertop.

H. USING THE CORNER INSERT METHOD (LAMINATED) FOR INSIDE CORNERS

Steps to completion:

1. Using material color-matched to the sheet, create blocks sufficient to make up the required buildup depth. Size the blocks to offset build up seams a minimum of 1" past the end of inside corner radius.

The number of blocks required in the Laminated Method can be calculated as follows: Countertop thickness divided by 12 mm ($\frac{1}{2}$ ") = number of blocks, rounded out to the greatest whole number.

2. Sand the blocks to ensure a perfectly flush face fit for all blocks.
3. Apply a perfectly even layer (i.e., no "S" pattern or similar), of DuPont™ Joint Adhesive or DuPont™ Joint Adhesive 2.0 to the faces of all blocks to be seamed.
4. Clamp the layers together and allow to set.
5. Upon setting, sand two return sides of the block to a smooth finish and scribe a perfect match to the buildup edge in the right angle inside corner of the DuPont™ Corian® sheet.
6. With the sheet placed upside-down on a level workbench, place a sheet of plastic underneath the edges of the inside corner.
7. Apply a generous quantity of DuPont™ Joint Adhesive or DuPont™ Joint Adhesive 2.0 to the face of the insert block and the edge of the sheet.

- Adhere the block into the right angle inside corner and clamp in position, ensuring that the face side of the block is approximately $\frac{1}{32}$ " (0.8 mm) above the countertop level and allow the adhesive to cure.
- Turn the sheet over and clamp a radius template in position.
- Use a router following the template and rout the inside corner radius.

I. USING THE CORNER INSERT METHOD (THERMOFORMED) FOR INSIDE CORNERS

Steps to completion:

- Using material color-matched to the DuPont™ Corian® sheet, create a block 2" x 2" (51 mm x 51 mm).
- Sand two return sides of the block to a smooth finish and scribe a perfect match to the face edge in the inside corner of the sheet.
- With the sheet placed upside-down on a level workbench, place a sheet of plastic underneath the edges of the inside corner.
- Apply a generous quantity of DuPont™ Joint Adhesive or DuPont™ Joint Adhesive 2.0 to the edges of the insert block and the edges of the sheet.
- Adhere the block into the inside corner and clamp in position, ensuring that the face side of the block is flush with the countertop level and allow to set.
- Clamp a template to the corner and, using a router, complete the inside corner radius, $\frac{1}{16}$ " (1.5 mm) oversize.
- Follow the instructions in *B. Rabbeting* the underside of the deck and complete a $\frac{5}{64}$ " x $\frac{1}{2}$ " (2.0 mm x 13 mm) rabbet around the edges of the countertop that require buildups.
- Using a piece of material color-matched to the sheet surface, prepare a strip of Corian® sheet the required depth of the buildup by a length which provides 4" (102 mm) returns from each end of the inside corner radius. Calculate the required depth of the buildup by subtracting the thickness of the sheet from the required countertop thickness plus the depth of the rabbet. Calculate the required length of the thermoformed piece by referring to the formula in the section above.
- Using the techniques detailed in *DuPont™ Corian® Solid Surface Fabrication/Installation Fundamentals – Thermoforming* (K-25297), thermoform the strip to the required radius.
- Glue the thermoformed buildup piece in the inside corner as described *G. Using the thermoformed method for inside corners*, steps 3 and 4.

J. USING THE LAMINATED METHOD FOR OUTSIDE CORNERS

Steps to completion:

- Using material color-matched to the countertop, create blocks 8" x 6" (203 mm x 152 mm) sufficient to make up the required buildup depth. The number of blocks required in the laminated method can be calculated by using the same method as for an inside corner.
- Sand the blocks to ensure a perfectly flush face fit for all blocks.
- Apply a perfectly even layer (i.e., no "S" pattern or similar) of DuPont™ Joint Adhesive or DuPont™ Joint Adhesive 2.0 to the faces of all blocks to be seamed.
- Clamp the layers together and allow to set.
- Upon setting, sand two return sides of the block to a smooth finish.
- Scribe outside radius, inside radius and returns onto block.
- Using a belt sander or router, remove the section to complete the outside radius.
- Using hot melt glue, adhere the partially completed block onto a secure work surface that allows room for a radius template.
- Clamp radius template to laminate block into position.
- Rout along the template to complete the piece.
- Double-check that the ends of the outside corner piece are well-finished and perfectly square.
- Finish as described in *F. Using the laminated method for inside corners*, steps 14–18.

K. USING THE THERMOFORMED METHOD FOR OUTSIDE CORNERS

Steps to completion:

- Using a piece of material color-matched to the sheet surface, prepare a strip of Corian® sheet the required depth of the buildup by a length which provides 4" (102 mm) returns from each end of the inside corner radius. Calculate the required depth of the build up by subtracting the thickness of the sheet from the required countertop thickness plus the depth of the rabbet. Calculate the required length of the thermoformed piece by using the formula described in the section on thermoformed inside corners.
- Using the techniques detailed in *DuPont™ Corian® Solid Surface Fabrication/Installation Fundamentals – Thermoforming*, thermoform the strip to the required radius.
- Finish as described in *G. Using the Thermoformed Method for inside corners*, steps 3 and 4.

L. LAMINATED METHOD ALTERNATIVES

The following are variations of the Laminated Method for making inside corners:

Drop Edge

Steps to completion:

1. Prepare blocks as described earlier. Be sure they are large enough to position the butt seams between the buildup strips and blocks at least 1" (25 mm) past the end of the radius on both sides of the block.
2. With top upside-down, dry-clamp block in the inside corner with the back of the block 1" (25 mm) from the front edge. Dry-fit the edge buildup pieces to the block and dry-clamp in place.
3. Cut two pieces of edge strip about 3" (76 mm) to 4" (102 mm) long and square on one end and beveled to 45° on the other end. Dry-fit the square end against the corner block. Dry-clamp these strips behind the front edge strips. Be sure that the backs of these strips are perfectly flush with the back of the corner block and that the tapered end dies into the back of the buildup strip.
4. Seam all pieces in place and together, and finish using the standard procedures described in *DuPont™ Corian® Solid Surface Fabrication/Installation Fundamentals – Finishing and Polishing* (K-25298). See Figure L-1.

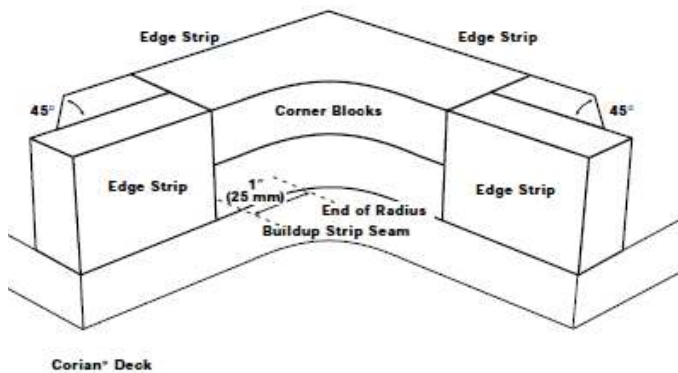

Figure L-1

HELPFUL HINT:

Use hot melt glue blocks to keep all pieces in position until adhesive sets.

Drop Edge Alternative

Steps to completion:

1. Prepare inside corner blocks as described earlier.
2. With the top upside down, dry-clamp the block into the inside corner with the back of the block 1/2" (12 mm) back from the front edge.
3. Dry-fit buildup strips to the sides of the block and dry-clamp in place.
4. Cut two strips long enough to overlap behind the corner block and extend about 2" (51 mm) past the butt seams between the buildups and the corner block. The overlapping ends may be left square but must be flush with each other. The opposite ends are to be tapered to 45° with the tapered ends dying into the front buildup strips.
5. Seam all pieces in place and to each other, and finish in the usual manner. See Figure L-2.

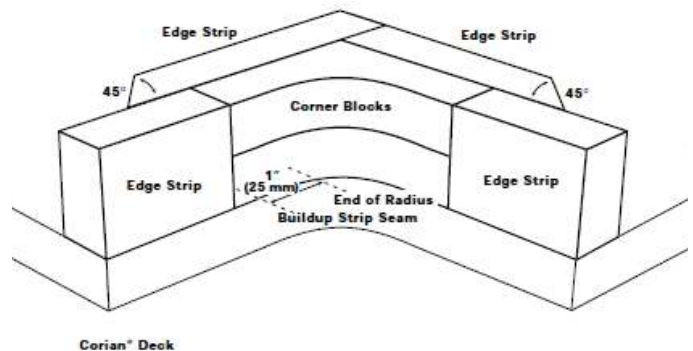

Figure L-2

Stack Front Edge

Steps to completion:

1. Cut blocks to form inside corner so that each layer is offset by 1/2" (13 mm) from the preceding layer. Be sure to size the block so that the edges of the smallest layer are at least 1" (25 mm) past the radius on both sides of the inside corner.
2. Place the countertop upside-down and dry-clamp the blocks in the inside corner so that a stair-step effect is seen where the buildup strips butt into the corner block. Be sure that the backs of the strips are perfectly flush with the corner blocks.
3. Dry-fit the edge strip pieces to the corner blocks and dry-clamp.
4. Apply enough hot melt glue blocks behind the edge strips and the corner blocks to ensure that all pieces will remain flush until after the adhesive sets.
5. Seam all pieces in place and to each other and finish in the usual manner. See Figure L-3.

EDGE DETAILS AND BUILDUPS

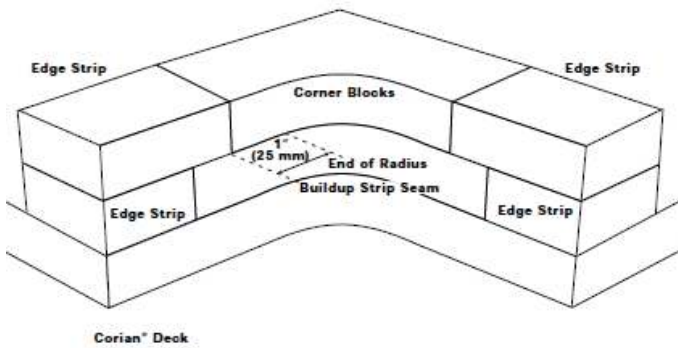

Figure L-3

M. STACK EDGE

The basic edge build up is the stack edge. The edge strips, of widths from 1" to 3", are applied in layers. This allows the edge pieces to rest on the cabinet eliminating the need for wood support strips along the front of the countertop.

Steps to completion:

1. To apply the edge detail, precut the strips and arrange them in layers overlapping the butt seams for added strength.
2. Stop blocks can be used to align layers during glue up. Use spring clamps to apply pressure until adhesive sets. Place clamps about 2" to 3" apart.
3. After the adhesive cures, trim excess adhesive using a router and straightedge.
4. Apply decorative edge profile as desired.

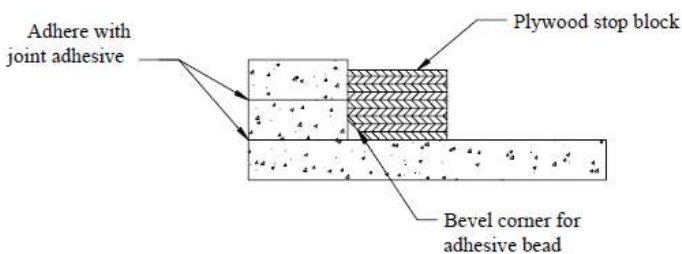

Figure M-1

5. Make inside corners as shown in Figure L 3. Outside corners may be made by simply butting the strips together or by alternating the seams in the layers. See Figure M-2.

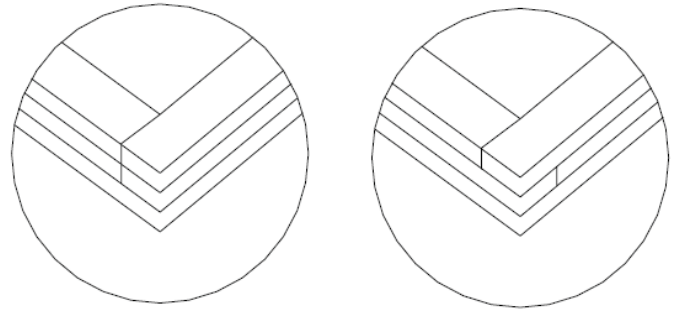

Figure M-2

HELPFUL HINTS:

Spring clamps can be angled to apply directional pressure to keep layers against stop blocks to keep butt seams from opening.

N. EDGE TREATMENTS

Other decorative edge treatments can create unique design elements to fabrication techniques.

Examples of popular edge treatments include:

- Bull nose
- Roundover
- Ogee
- Chamfered

Fabrication techniques for all edge treatments are the same, using different router bits to create the distinctions.

Steps to completion:

1. Upon completion of attachment of all buildup, including inside and outside corners, use a flush-cut trimmer or router and straightedge to finish buildup flush and square with countertop.
2. Sand smooth any edge imperfections.
3. Select the appropriate router bit, ensuring the bit is fitted with a roller bearing, and place this in a 1¹/₂-hp router or larger.
4. Routing from left to right, rout all edges on the face side of the countertop. Make sure that the router is kept level and square on the countertop.
5. Turn the countertop over and repeat step 4 on the bottom edge of the buildup if required.

HELPFUL HINTS:

Conduct a trial run on a scrap piece of material to check depth and shape of router cut before completing any edge treatment on finished work.

Do not rush or force the router, as rushing causes a rougher cut which requires more finishing.

Some manufacturers make router bits that will shape the underside of the countertop edge without needing to turn the top over.

O.V –GROOVE EDGES

V-Grooving, or Cut-and-fold, was originally developed for woodworking and laminates. Advantages are process speed and hidden seams. Surface aesthetics, such as veining, can be continuous around edges with this technique. More complicated shapes such as folded edges and cove backsplashes can be easily formed at no additional cost. See Figure O-1.

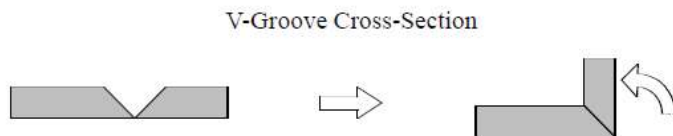

Figure O-1

Tools and Equipment:

- Dedicated V-groove machine.
- Other equipment modified for V-grooving - Vertical Panel Saw
- V-Groove tooling (Cutters may be C4-carbide or diamond; brazed or insert style tool configuration)
- Clamps or clamp table
- Corner clamps
- V-grooving tape
- Compressed air and nozzle
- Router and bits
- Palm sander
- DuPont™ Joint Adhesive or DuPont™ Joint Adhesive 2.0
- Hot melt glue and pressure-feed glue gun

Steps to Completion:

1. Set up machine.

Caution: Do not set V-groove cutter to penetrate completely through sheet. Leave the thickness of a business card at the bottom of the groove.

2. Cut Corian® solid surface piece to overall size.
3. Energize machine and make horizontal cuts as required.
4. Repeat steps as necessary until all cuts have been made.

Bonding Groove Joints:

Steps to completion:

1. Remove all dust from grooves with denatured alcohol¹.

If the piece has been sitting for 24 hours or longer since the grooves were cut, they may be contaminated with airborne oil or moisture condensate. Wipe the grooves with a clean lint-free rag moistened with denatured alcohol.

2. Prepare DuPont™ Joint Adhesive or DuPont™ Joint Adhesive 2.0 cartridge following instructions.
3. Apply a 1/8" (3-mm) bead of adhesive in the very bottom of the groove (see Figure O-2). Wait 30 seconds to 1 minute for any trapped air to escape.

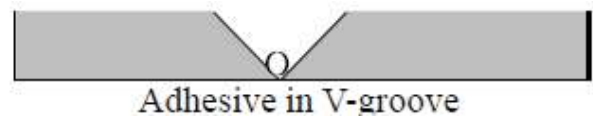

Figure O-2

4. Slowly fold the piece to close the groove, allowing adhesive to flow upward and fill the joint as the groove closes. A small amount of excess adhesive should squeeze out of the joint in the corner.

CAUTION: Don't allow the joint to re-open, or air bubbles will enter the joint.

5. Clamp the piece in position for 45 minutes. When clamping, apply force directly against the tape behind the glued joint, not at the ends of the piece.
 - Use sliding clamps spaced approximately 18 inches (46 cm) apart.
 - For joints near the end of a long piece, temporarily glue a clamping block to the piece with hot melt glue and modify the clamp as shown in Figure O-3.

¹Denatured alcohol is the preferred solvent for cleaning DuPont™ Corian® solid surface products. Acetone is approved for cleaning DuPont™ Corian® solid surface in regions where denatured alcohol is prohibited. Please see DuPont™ Corian® Solid Surface Fabrication/Installation Fundamentals – Approved Cleaning Solvents (K-25701) for more details.

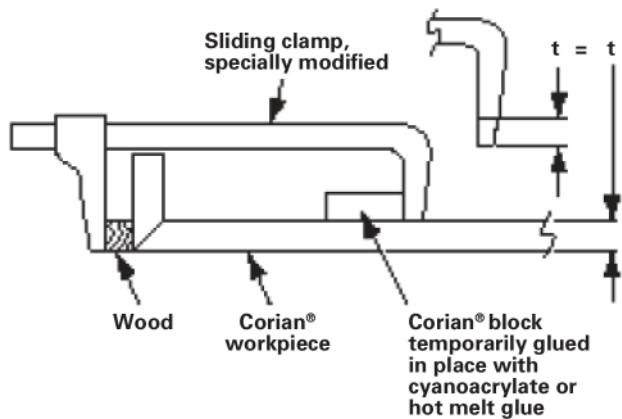

Figure O-3

- For production runs, use a clamping table Figure O-4.

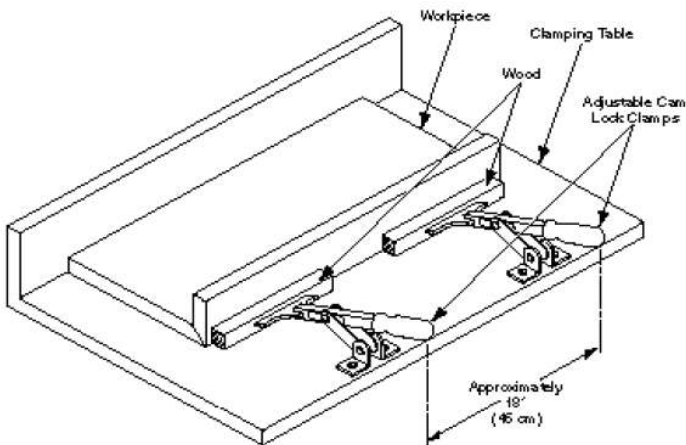

Figure O-4

P. APRON SUPPORT

Often the apron or skirt is subjected to the most wear and tear of any part of the installation, especially in commercial applications. In order to have a long-lasting installation, additional support is essential in instances where the edge piece extends greater than 2" (51 mm) beyond the frame support.

This additional support can be formed in either of two ways:

1. Triangular brackets of DuPont™ Corian® solid surface adhered to countertop and apron with joint adhesive.

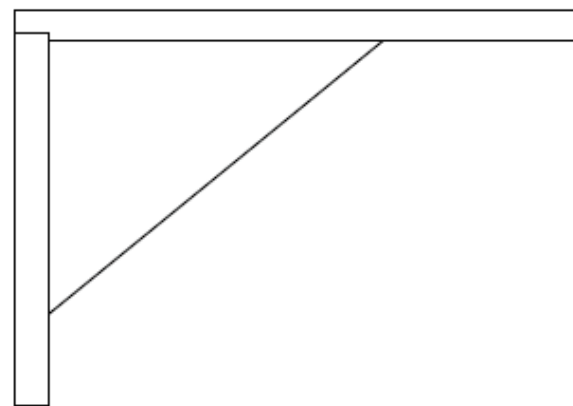

Figure P-1

2. Mechanical (frame) supports.

Triangular Bracket Fixing:

Steps to completion:

1. If no mechanical support is possible, construct triangular brackets made from 12 mm (1/2") Corian® sheet.
2. Place brackets every 20" (508 mm).
3. Glue brackets to countertop and apron using DuPont™ Joint Adhesive or DuPont™ Joint Adhesive 2.0.

Mechanical Supports:

Steps to completion:

1. Upon completion of the countertop and apron, identify where mechanical support can be attached.
2. Alternative mechanical support can be made through creating an "L" bracket under support or "U" channel under support.

HELPFUL HINTS:

If the apron will conceal light fixtures for down lighting, some of the more translucent colors may transmit enough light to reveal shadows from the support structure. A coat of acrylic paint on the inside surface of the apron will prevent light transmission.

Triangular brackets should be the same thickness as the apron.

Aprons are typically at a height that they are subject to impact. Support behind the apron is a safeguard against cracking and seam failure.

EDGE DETAILS AND BUILDUPS

Q. REFERENCED DOCUMENT

*DuPont™ Corian® Solid Surface Fabrication/Installation
Fundamentals – Thermoforming (K-25297)*

*DuPont™ Corian® Solid Surface Fabrication/Installation
Fundamentals – Finishing and Polishing (K-25298)*

This information is based on technical data that E.I. du Pont de Nemours and Company and its affiliates ("DuPont") believe to be reliable, and is intended for use by persons having technical skill and at their own discretion and risk. DuPont cannot and does not warrant that this information is absolutely current or accurate, although every effort is made to ensure that it is kept as current and accurate as possible. Because conditions of use are outside DuPont's control, DuPont makes no representations or warranties, express or implied, with respect to the information, or any part thereof, including any warranties of title, non-infringement of copyright or patent rights of others, merchantability, or fitness or suitability for any purpose and assumes no liability or responsibility for the accuracy, completeness, or usefulness of any information. This information should not be relied upon to create specifications, designs, or installation guidelines. The persons responsible for the use and handling of the product are responsible for ensuring the design, fabrication, or installation methods and process present no health or safety hazards. Do not attempt to perform specification, design, fabrication, or installation work without proper training or without the proper personal protection equipment. Nothing herein is to be taken as a license to operate under or a recommendation to infringe any patents. DuPont shall have no liability for the use of or results obtained from such information, whether or not based on DuPont's negligence. DuPont shall not be liable for (i) any damages, including claims relating to the specification, design, fabrication, installation, or combination of this product with any other product(s), and (ii) special, direct, indirect or consequential damages. DuPont reserves the right to make changes to this information and to this disclaimer. DuPont encourages you to review this information and this disclaimer periodically for any updates or changes. Your continued access or use of this information shall be deemed your acceptance of this disclaimer and any changes and the reasonableness of these standards for notice of changes.

© E.I. du Pont de Nemours and Company 2015. The DuPont Oval, DuPont™, The miracles of science™, and Corian® are trademarks or registered trademarks of E.I. du Pont de Nemours and Company ("DuPont") or its affiliates. All rights reserved.