



Corian.
CHARGING SURFACE

DUPONT™ CORIAN® CHARGING UNIT – INDIVIDUAL: ZODIAQ® INSTALLATION

INTRODUCTION

This bulletin discusses the procedure for installation of the DuPont™ Corian® Charging Unit – Individual wireless charging transmitter in DuPont™ Zodiaq® Quartz Surfacing.

OVERVIEW

The DuPont™ Corian® Charging Unit – Individual dual-mode transmitter is compliant with PMA and WPC Qi standards.

The transmitter is tuned for best performance when installed through 10 mm (0.394") of Zodiaq® quartz surface.

Instructions for optimum placement and installation are in this bulletin. Due to the precise routing required and the potential for silica dust generation, the installation should be done in the fabrication shop prior to slab installation.

The DuPont™ Corian® Charging Unit – Individual package consists of the transmitter, power cord and transformer. PMA compliant charging rings are available separately in packs of three: one ring each of micro USB, Apple 30-pin and Apple Lightning® PMA compatible receivers.

The transmitter has a micro USB port for updating the firmware if necessary.

A. PREPLANNING

A.1. Box Contents

The box will come with the transmitter and the power supply (not pictured here).



Figure A-1: Transmitter

A.2. Available Separately

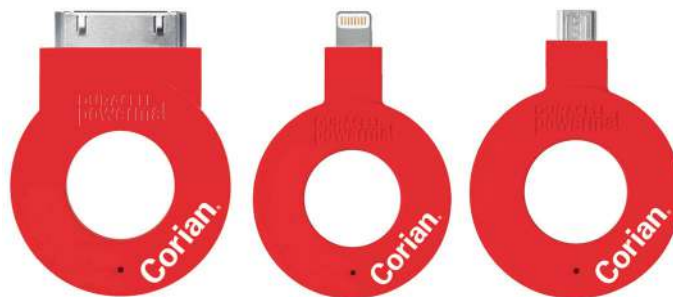

Figure A-2: Adapter rings: Apple Lightning®, Apple 30-pin, micro USB

A.3. Placement

There are several considerations regarding proper placement of the transmitter:

- Avoid putting in proximity to locations where the device being charged may get wet, exposed to excessive heat or any other conditions which may damage the device being charged.
- Do not install next to heat sources (such as stoves) or where heat sources are commonly used (toasters, hot plates, etc.).
- Stay away from edges where charging devices can be easily knocked off the surface.

Work with the customer to determine convenient locations.

DUPONT™ CORIAN® CHARGING UNIT – INDIVIDUAL: ZODIAQ® INSTALLATION

The transmitter requires a rectangular space of 82 mm x 92 mm (3.23" x 3.60") below the surface counter. Do not install within 25mm (1") of any support structure. No metal should be between the transmitter and the surface. The transmitter also requires 36 mm (1 7/16") vertical clearance measured from the top surface (24 mm (0.94") from bottom surface). Avoid placement above heat- or moisture-generating appliances such as dishwashers, warming drawers, wine refrigerators, etc. Verify cabinet/support measurements before cutting the top. There should be a support strip between the transmitter and any cutouts or the edge of the top.

The transmitter does generate some heat and ideally is installed such that it shares airspace with the cabinet interior.

If placing above a drawer, make sure there is sufficient clearance, including drawer contents.

Install so that the transmitter will be accessible by the customer. If there is a warranty replacement the customer will need to be able to remove and replace the transmitter. Make sure the power and micro USB ports will be accessible after installation. Plan for power cable routing and mounting of the transformer. The power supply has a 1.2 m (47") DC cable, 111 mm x 51 mm x 36 mm (4.4" x 2.0" x 1.4") transformer 1.2 m (47") AC cable. A four-unit power supply is available separately.

If more than one transmitter is installed they should be at least 150 mm (6") from each other.



Figure A-3: Left - Power, Center - Micro USB, Right - LED

A.4. Marking Charging Location

Stickers are available for temporary marks until the customer becomes familiar with the charging location.

A.5. Additional Materials and Equipment

In addition to the transmitter, fabrication will require 100% silicone adhesive, denatured alcohol and a clean cloth. Using a CNC is highly recommended for accurately cutting the cavity.

Some form of cable management (conduit, clips, etc.) will be necessary.

B. VERIFY TRANSMITTER OPERATION

B.1. Important Testing Guidance

Verify the transmitter is operational before installing by plugging it in. A green LED should blink once.

DO NOT TEST BY PLACING A RECEIVER IN CONTACT WITH THE TRANSMITTER.

The transmitter is optimized for the installation distance, bringing the transmitter and receiver in direct contact may damage the devices. Always test with something nonmetallic of 8 mm (0.315") or greater thickness in between the transmitter and receiver.

B.2. Firmware Updates

When there is a firmware update, DuPont will make the update available for download. The transmitter is updated by connecting the device to a computer using a USB 2.0 Micro Type-B to USB Standard Type-A cable.

C. SLAB PREPARATION

C.1. Marking Location

Stickers are available to mark the charging spot until the customer can "learn" the location.

C.2. Milling Pocket

The wireless power transmitter is optimized for a surface thickness of 10 mm (0.394"). A CNC is highly recommended for pocket milling as the distance is registered from the face of the slab.

The pocket should be milled as a circle of 63.5 mm (2.5") leaving the remaining material thickness of 10 mm (0.394") from the Zodiaq® surface. Use a finger bit with a 3 mm (0.118") radius on the tip for a uniform surface in the cavity. A cavity for the flange and clearance for cables must be milled as well. The remaining thickness at the flange will be 14 mm

DUPONT™ CORIAN® CHARGING UNIT – INDIVIDUAL: ZODIAQ® INSTALLATION

(0.551"). As all measurements are referenced off the face of the slab, the guidance is the same for 2 and 3 cm slabs, but the depth cut and time required will be greater for 3 cm slabs.

Make sure that once the transmitter is installed there will be clearance for attaching the power plug and that there is access to the micro USB port for potential firmware updates.

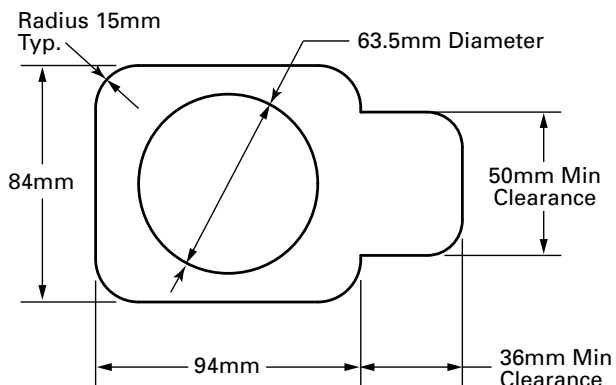

Figure C-1: Cutout Dimensions

D. TRANSMITTER INSTALLATION

D.1. Adhering transmitter to slab

Remove all dust. Clean the slab and flange of the transmitter with a clean cloth dampened with denatured alcohol¹. Verify the desired orientation of the transmitter so that the power and USB ports will be accessible after installation. The flange will sit slightly above the milled surface when the coil is in contact with the cavity surface.



Figure D-1: Transmitter top surface

¹Where regulations require, alternative solvents are discussed in *DuPont™ Corian® Solid Surface Fabrication/Installation Fundamentals – Approved Cleaning Solvents* (K-25701)



Figure D-2: 100% Silicone applied to transmitter

The transmitter is attached to the slab with a 100% silicone adhesive. Place dabs of silicone at each of the four corners. Clear or translucent adhesive is recommended, white is shown here for visibility. There needs to be enough silicone to fill the gap between the flange and the surface. Keep the silicone away from the coil. If for some reason the transmitter will be replaced, removal will be easier if the adhesive is only on the flange and not in the cavity. If desired, small amounts of hot melt adhesive may be placed along opposite sides to hold the transmitter in place while the silicone adhesive cures. The hot melt can be applied at the edges of the flange after the transmitter is placed in the pocket. The transmitter may be held in place with tape or a weight while the silicone cures.

Hot melt adhesive is for temporary bonding only. It is not suitable for long term mounting.



Figure D-3: Transmitter adhered to surface



DUPONT™ CORIAN® CHARGING UNIT – INDIVIDUAL: ZODIAQ® INSTALLATION

Break all sharp edges

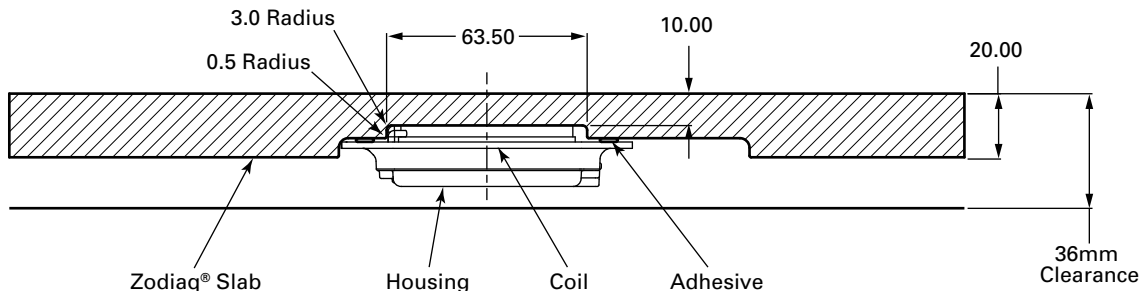

Figure D-4: Installation Summary Schematic 2 CM (all measurements in mm)

Break all sharp edges

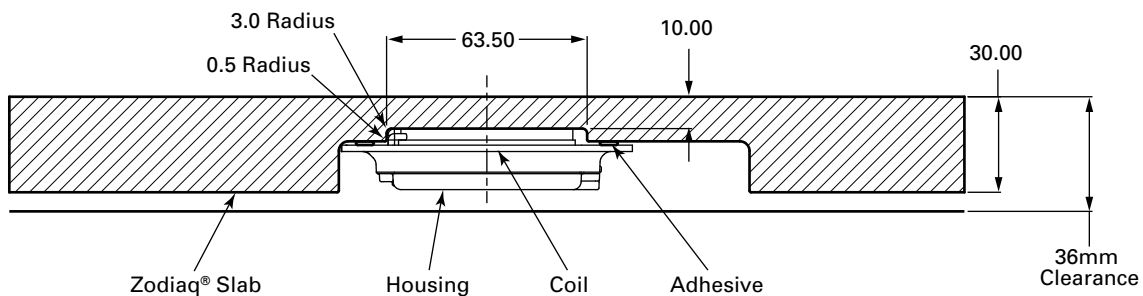

Figure D-5: Installation Summary Schematic 3 CM (all measurements in mm)

D.2. Wiring

The transmitter is supplied with a power cord consisting of DC and AC wiring connected with a transformer. In many cases an AC power outlet may need to be installed in the cabinetry where the transmitter is to be installed. Local codes must be followed and the AC outlet often must be installed by a licensed electrician.

E. LED INDICATOR

The LED will indicate the current transmitter status.

| | |
|-------------------------|---------------------------|
| Off | No power/inactive |
| Power On | One green flash |
| Charging | Continuous flashing green |
| End-of-charge | Solid green |
| Foreign object detected | Flashing red |
| Error condition | Solid red |

F. TRANSPORTATION

The greatest risk of physical damage to the transmitter will be between transmitter installation and fabricated top installation in the facility. Protect the transmitter during storage and transportation. One option for protecting the transmitter is to cut a cavity large enough to contain the transmitter in a piece of stiff foam. This foam can then be taped over the transmitter for protection.

G. REFERENCES

DuPont™ Corian® Solid Surface Fabrication/Installation Fundamentals – Approved Cleaning Solvents (K-25701)

This information is based on technical data that E.I. du Pont de Nemours and Company and its affiliates ("DuPont") believe to be reliable, and is intended for use by persons having technical skill and at their own discretion and risk. DuPont cannot and does not warrant that this information is absolutely current or accurate, although every effort is made to ensure that it is kept as current and accurate as possible. Because conditions of use are outside DuPont's control, DuPont makes no representations or warranties, express or implied, with respect to the information, or any part thereof, including any warranties of title, non-infringement of copyright or patent rights of others, merchantability, or fitness or suitability for any purpose and assumes no liability or responsibility for the accuracy, completeness, or usefulness of any information. This information should not be relied upon to create specifications, designs, or installation guidelines. The persons responsible for the use and handling of the product are responsible for ensuring the design, fabrication, or installation methods and process present no health or safety hazards. Do not attempt to perform specification, design, fabrication, or installation work without proper training or without the proper personal protection equipment. Nothing herein is to be taken as a license to operate under or a recommendation to infringe any patents. DuPont shall have no liability for the use of or results obtained from such information, whether or not based on DuPont's negligence. DuPont shall not be liable for (i) any damages, including claims relating to the specification, design, fabrication, installation, or combination of this product with any other product(s), an (ii) special, direct, indirect or consequential damages. DuPont reserves the right to make changes to this information and to this disclaimer. DuPont encourages you to review this information and this disclaimer periodically for any updates or changes. Your continued access or use of this information shall be deemed your acceptance of this disclaimer and any changes and the reasonableness of these standards for notice of changes.

© E.I. du Pont de Nemours and Company 2015. The DuPont Oval, DuPont™ and Corian® are trademarks or registered trademarks of E.I. du Pont de Nemours and Company ("DuPont") or its affiliates. All rights reserved.

Apple Lightning® is a registered trademark of Apple, Inc.
K-28989 7/15