

## EDGE DETAILS AND BUILDUPS

### NO-DRIP EDGE

#### 12.13 NO-DRIP EDGE

To construct a no-drip edge, unlike other edge details, the buildup must be face-applied.

To apply the edge detail, three-way C-clamps or standard pipe clamps can be used to apply pressure and enable the seam to be glued.

One recommended method is to form a tongue on the Corian® sheet and a groove into the edge detail to allow for firm and accurate seaming to take place. See Figure 12.13.A.

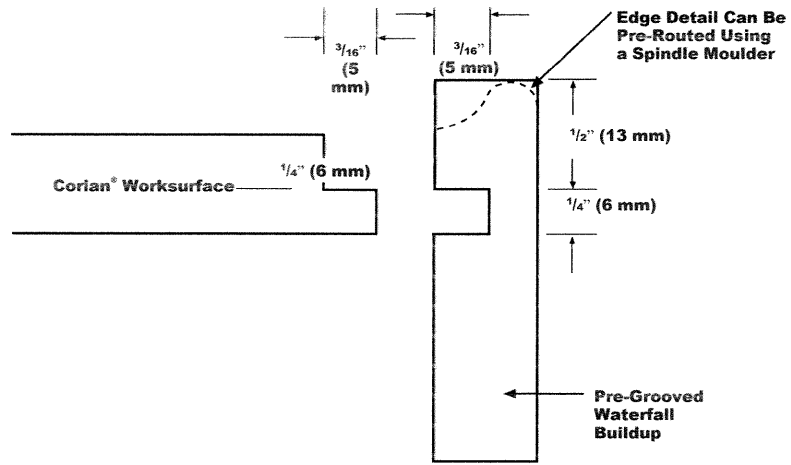

The no-drip detail can be premade using a shaper or alternatively can be done with a handheld router using a no-drip router bit as illustrated in Figure 12.13.B.

Figure 12.13.B

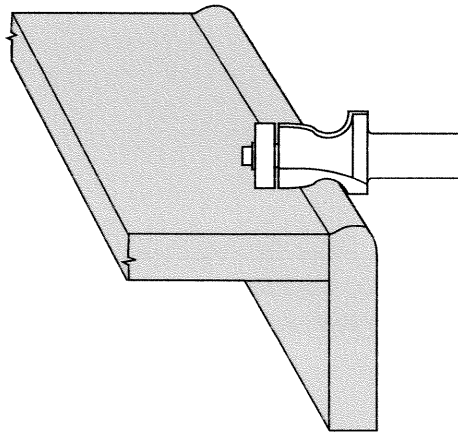

#### Helpful Hints:

Use great care with no-drip bits as the bearings get clogged quickly and can seize up, damaging the top.