

## COUNTERTOP — OVERHANGS

This describes how to fabricate and install Corian® countertops that overhang up to 18" (457 mm).

### Fabricating and Installing Overhang Countertops

#### Supporting Overhangs

As a general guideline, support is required for overhangs of Corian® containing seams or for 1/2" (13 mm) overhangs extending more than 6" (150 mm) and 3/4" (19 mm) overhangs extending more than 12" (300 mm). Adding thick edges makes the overhang stronger.

#### Support Types

Refer to the following charts to determine the type(s) of support to use.

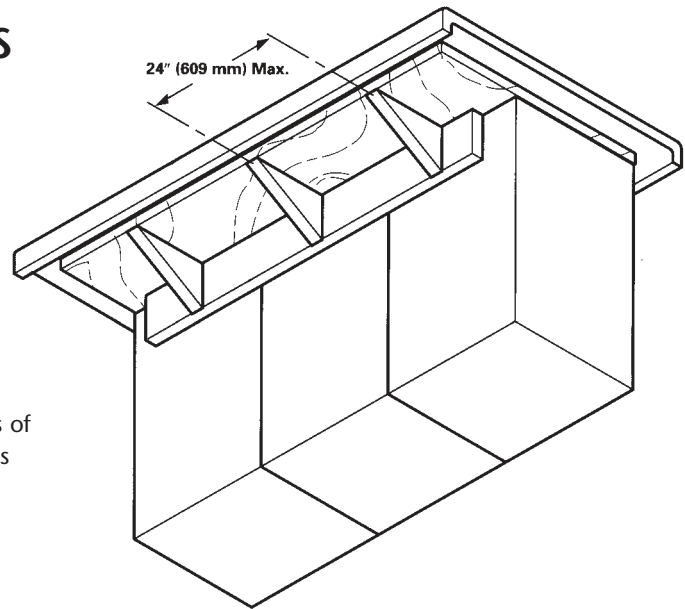

#### Overhang Supports

FOR OVERHANGS EXTENDING MORE THAN	AND UP TO	INSTALL
<b>1/2" (13 mm) Corian® Countertop</b>		
0" (0 mm)	6" (150 mm)	No Additional Support Required
6" (150 mm)	12" (300 mm)	Plywood Underlayment <i>or</i> Brackets of Corian®
12" (300 mm)	18" (457 mm)	Plywood Underlayment <i>and</i> Brackets of Corian®
18" (457 m)	—	Legs or Columns

#### Seamed Overhang Supports\*

FOR COUNTERTOPS WIDER THAN	INSTALL
30" (760 mm)	Plywood Underlayment <i>and</i> Reinforcing Strips and/or Edge Buildups of Corian®

\*All seams must be supported. For countertops wider than 30" (760 mm), put the seam in the overhang, not over the cabinet.

C950-K03158-44 1/04

The information contained in this Technical Bulletin is given by E.I. du Pont de Nemours and Company free of charge. It is based on technical data which DuPont believes to be reliable and is intended for use by persons having knowledge of this technical area at their own discretion and risk. Seller assumes no responsibility for results obtained or damage incurred from the use of this Technical Bulletin either in whole or in part by a buyer of Corian®. Corian® is a DuPont registered trademark for its solid surfaces. Only DuPont makes Corian®. Copyright © 2004 E.I. du Pont de Nemours and Company. Printed in the U.S.A.

DuPont™  
**CORIAN®**  
SOLID SURFACES



The miracles of science™